

104系列永磁无刷齿轮减速电机

104 SERIES OF BRUSHLESS DC MOTOR

电机基本特性 Basic Characteristics Of Motor

● 200W (DC电源时适用于24VDC/36VDC/48VDC) 200W (DC Power Supply When Applied To 24VDC/36VDC/48VDC)

额定功率(连续) Rated power (Continuous)	W	200(200W/400W)			
额定转速 Rated speed	r/min	3000			
额定转矩 Rated torque	N.m	0.636			
瞬时最大转矩 Instantaneous maximum torque	N.m	0.955			
转子转动惯量 Rotor moment of inertia	J:×10 ⁻⁴ kg.m ²	0.460			
速度控制范围 Speed control range	RPM	高压High pressure 200-2500RPM (低压Low pressure 200-3000RPM)			
速率变化率 Speed control range	对负载 On load	±1.0%以下: 条件 0~额定转矩、额定转速、额定电压、常温 Below ±1%: condition 0~rated torque, rated speed, rated voltage, room temperature			
	对电压 On voltage	±1.0%以下: 条件 额定电压±10%、额定转速、额定负载、常温 Below ±1%: condition rated voltage ±10%, rated speed, rated load, room temperature			
	对温度 On temperature	±1.0%以下: 条件使用环境温度-10°C~+40°C额定转速、额定负载、额定电压 Below ±1%: Conditions of ambient temperature -10°C~+40°C rated voltage, rated load and rated speed			
电源输入 Power input	额定电压 Rated voltage	V	单相Single phase 110V	单相Single phase 220V	
	电压容许范围 Voltage tolerance range		±10%		
	频率 Frequency	Hz	50/60	/	
	频率容许范围 Frequency tolerance range		±5%	/	
	额定输入电流 Rated input current	A	4.7	2.4	7.5
	瞬时最大输入电流 Instantaneous maximum input current	A	9.0	4.8	11.5

圆轴型光电机 Circular Shaft Type Optical Motor

● Z6BLD200-□A-30S □—电压 Voltage 24/36/48/110/220

● Z6BLD200-220A-30S 曲线图 Diagram
(ZD标准驱动器 ZD Standard Drive)

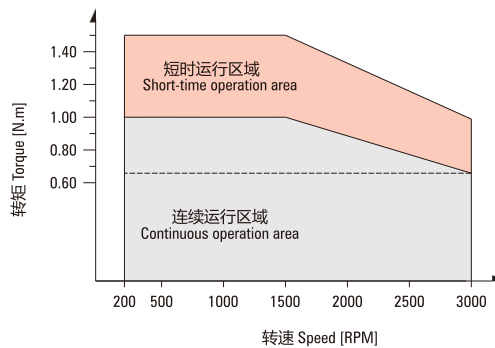
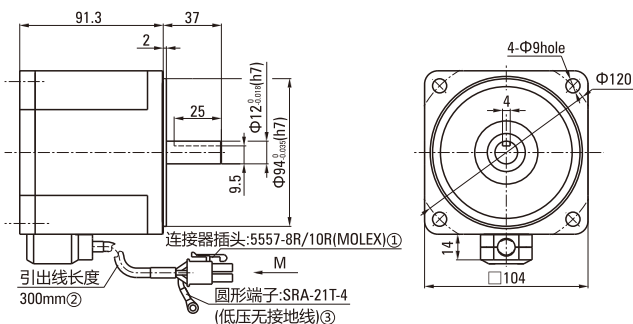

①Connector: 5557-8R/10R (MOLEX) ②Lead wire length 300mm ③Round terminal: SRA-21T-4 (Low ground)

● 低压电机接线插孔对应信号说明

Low Voltage Wrie Plughole Corresp-onding Signal Explanation

5	6	7	8	1	2	3	4	5	6	7	8
绿(粗)	黑(细)	蓝(细)	红(细)	黄(粗)	蓝(粗)	绿(细)	黄(细)	绿(粗)	黑(细)	蓝(粗)	黄(细)
1	2	3	4	V	GND	Hv	Vcc+5V	U	W	Hv	Hu

● 高压电机接线插孔对应信号说明

High Voltage Wrie Plughole Corresp-onding Signal Explanation

6	7	8	9	10	1	2	3	4	5	6	7	8	9	10
黄(粗)	绿(细)	蓝(细)	金属丝网	黑(粗)	蓝(粗)	黄(粗)	绿(粗)	红(细)	黄(粗)	绿(细)	蓝(粗)	黄(细)	绿(粗)	红(细)
1	2	3	4	5	Hu	Hv	Hw		GND	W	U	V		Vcc+5V

200W

● 平行轴减速机 Parallel Shaft Speed Reducer

Z6BLD200-□GU-30S/6GU□K □—电压 Voltage 24/36/48/110/220
□—速比数值 Velocity Ratio Value

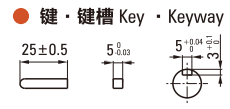
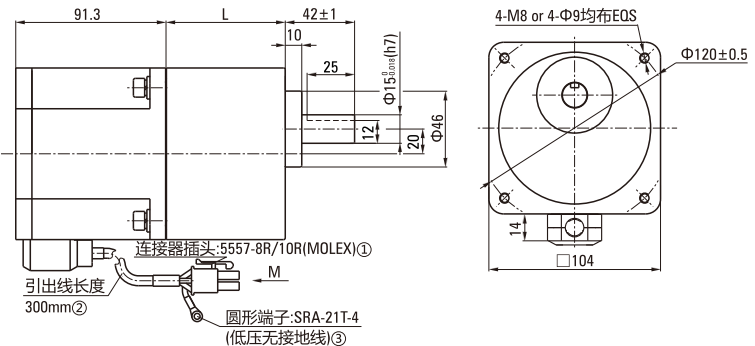

减速器型号 Gearhead Model	减速比 Gear Ratio	L尺寸 Dimension
6GU□K	3~200	72

● 减速器型号的□中为减速比的数值
Enter the gear ratio in the box (□) within the model name

①Connector: 5557-8R/10R (MOLEX) ②The sheath length of lead line 300mm ③Round terminal: SRA-21T-4 (Low ground)

● Z6BLD200-□GU-30S/6GU□K整机容许力矩 (单位: N.m) Z6BLD200-□GU-30S/6GU□K Machine Allowable Torque (Unit: N.m)

型号 Model	电机轴转速 Motor Speed	减速比 Reduction Ratio																				
		3	3.6	5	6	7.5	9	12.5	15	18	25	30	36	50	60	75	90	100	120	150	180	200
Z6BLD200-□GU	200~1500RPM	2.41	2.90	4.02	4.83	6.03	7.24	9.06	10.9	13.1	16.4	19.7	23.6	32.8	39.3	40.0	40.0	40.0	40.0	40.0	40.0	40.0
	2000RPM	2.04	2.45	3.40	4.08	5.11	6.13	7.67	9.20	11.0	13.9	16.6	20.0	27.7	33.3	40.0	40.0	40.0	40.0	40.0	40.0	40.0
	2500RPM	1.86	2.23	3.09	3.71	4.64	5.57	6.97	8.37	10.0	12.6	15.1	18.2	25.2	30.3	37.8	40.0	40.0	40.0	40.0	40.0	40.0
	3000RPM	1.55	1.86	2.58	3.09	3.87	4.64	5.81	6.97	8.37	10.44	12.53	15.04	20.88	25.06	31.32	37.59	40.0	40.0	40.0	40.0	40.0

● Z6BLD400-□GU-30S/6GU□K整机容许力矩 (单位: N.m) Z6BLD400-□GU-30S/6GU□K Machine Allowable Torque (Unit: N.m)

型号 Model	电机轴转速 Motor Speed	减速比 Reduction Ratio																				
		3	3.6	5	6	7.5	9	12.5	15	18	25	30	36	50	60	75	90	100	120	150	180	200
Z6BLD400-□GU	200~1500RPM	4.82	5.80	8.04	9.66	12.06	14.48	18.12	21.8	26.2	32.8	39.4	40.0	40.0	40.0	40.0	40.0	40.0	40.0	40.0	40.0	40.0
	2000RPM	4.08	4.90	6.80	8.16	10.22	12.26	15.34	18.4	22.0	27.8	33.2	40.0	40.0	40.0	40.0	40.0	40.0	40.0	40.0	40.0	40.0
	2500RPM	3.72	4.46	6.18	7.42	9.28	11.14	13.94	16.74	20.0	25.2	30.2	36.4	40.0	40.0	40.0	40.0	40.0	40.0	40.0	40.0	40.0
	3000RPM	3.09	3.71	5.16	6.19	7.74	9.28	11.62	13.94	16.73	20.88	25.06	30.07	40.0	40.0	40.0	40.0	40.0	40.0	40.0	40.0	40.0

注: 表格中的□ (灰底部分) 表示旋转方向与电机转向一致。The □ (gray) in the table indicates that the rotation direction is consistent with the motor.
(不同转速及速比下的力矩为ZD标准驱动器下测试所得。The torque under different speed and speed ratio is obtained under the ZD standard.)

● L型减速机 L Type Speed Reducer

Z6BLD200-□GUL-30S/6GU□LC □—电压 Voltage 24/36/48/110/220
□—速比数值 Velocity Ratio Value

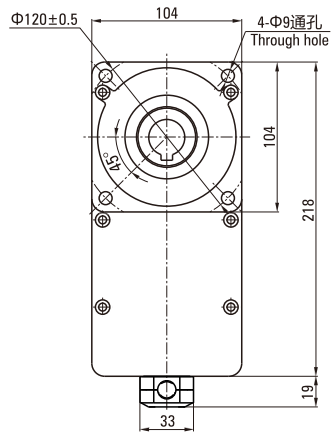
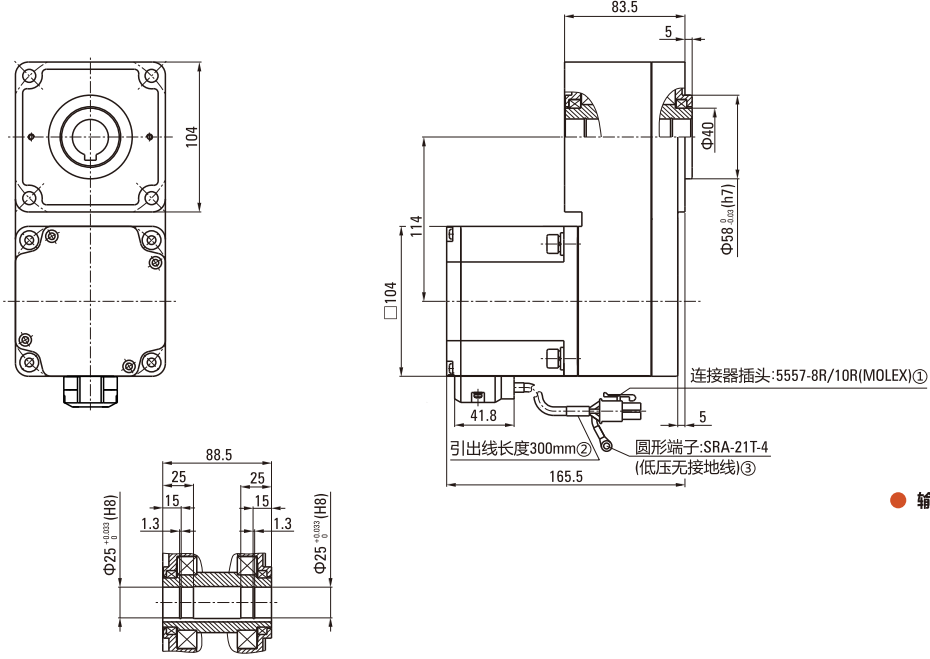

● 输出轴内孔结构 The Output Shaft Hole Structure

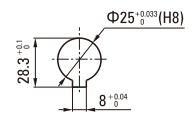

①Connector: 5557-8R/10R (MOLEX) ②Lead wire length 300mm ③Round terminal: SRA-21T-4 (Low ground)

● Z6BLD200-□GU-30S/6GU□LC 整机容许力矩 (单位: N.m) Z6BLD200-□GU-30S/6GU□LC Machine Allowable Torque (Unit: N.m)

电机轴转速 Motor Speed	减速比 Reduction Ratio						
	5	15	20	30	40	50	100
200~1500RPM	4.02	12.1	16.10	21.80	32.20	40.20	80.40
2000RPM	3.40	10.2	13.60	20.40	27.20	34.00	68.00
2500RPM	3.09	9.27	12.36	18.54	24.72	30.90	61.80
3000RPM	2.32	6.96	9.280	13.92	18.56	23.20	46.40

● Z6BLD400-□GU-30S/6GU□LC 整机容许力矩 (单位: N.m) Z6BLD400-□GU-30S/6GU□LC Machine Allowable Torque (Unit: N.m)

电机轴转速 Motor Speed	减速比 Reduction Ratio						
	5	15	20	30	40	50	100
200~1500RPM	8.04	24.20	32.20	43.60	64.40	80.40	120.0
2000RPM	6.80	20.40	27.20	40.80	54.40	68.00	120.0
2500RPM	6.18	18.54	24.72	37.08	49.44	61.80	120.0
3000RPM	4.64	13.92	18.56	27.84	37.12	46.40	92.80

注Note: 表格中的所有速比旋转方向与电机转向相反。All gearbox output turn direction in form are opposite as motor turn direction.
(不同转速及速比下的力矩为ZD标准驱动器下测试所得。The torque under different speed and speed ratio is obtained under the ZD standard.)

● 弧锥直角减速电机 Arc Cone Right Angle Speed Reducer Motor

Z6BLD200-□GU-30S/6GU□RC □—电压 Voltage 24/36/48/110/220
□—速比数值 Velocity Ratio Value

Z6BLD200-□GU-30S/6GU□RT □—电压 Voltage 24/36/48/110/220
□—速比数值 Velocity Ratio Value

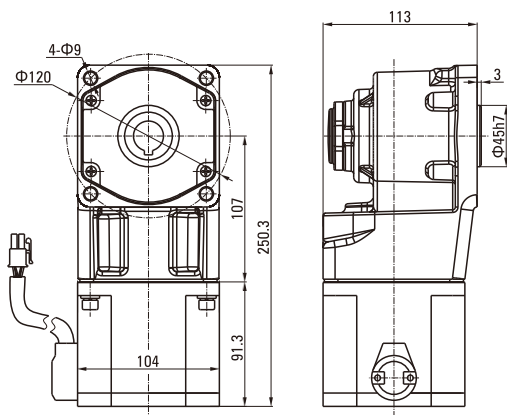

输出轴内孔结构

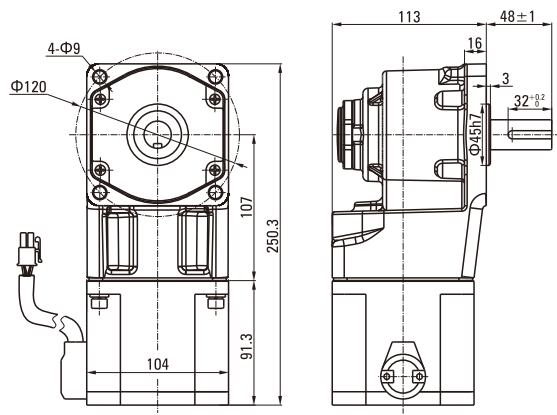
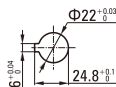

输出轴结构

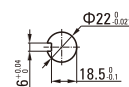

● Z6BLD200-□GU-30S/6GU□RC/RT 整机容许力矩 (单位: N.m) Z6BLD200-□GU-30S/6GU□RC/RT Machine Allowable Torque (Unit: N.m)

型号 Model	电机轴转速 Motor Speed	减速比 Reduction Ratio																	
		7.5	9	12.5	15	18	25	30	36	50	60	75	90	100	120	150	180	200	
Z6BLD200-□GU	200~1500RPM	6.03	7.24	9.06	10.9	13.1	16.4	19.7	23.6	32.8	39.3	40.0	40.0	40.0	40.0	40.0	40.0	40.0	40.0
	2000RPM	5.11	6.13	7.67	9.20	11.0	13.9	16.6	20.0	27.7	33.3	40.0	40.0	40.0	40.0	40.0	40.0	40.0	40.0
	2500RPM	4.64	5.57	6.97	8.37	10.0	12.6	15.1	18.2	25.2	30.3	37.8	40.0	40.0	40.0	40.0	40.0	40.0	40.0
	3000RPM	3.15	3.78	5.25	6.30	7.56	10.51	12.61	15.13	23.24	27.89	34.86	40.0	40.0	40.0	40.0	40.0	40.0	40.0

● Z6BLD400-□GU-25S/6GU□RC/RT 整机容许力矩 (单位: N.m) Z6BLD400-□GU-25S/6GU□RC/RT Machine Allowable Torque (Unit: N.m)

型号 Model	电机轴转速 Motor Speed	减速比 Reduction Ratio																	
		7.5	9	12.5	15	18	25	30	36	50	60	75	90	100	120	150	180	200	
Z6BLD400-□GU	200~1500RPM	12.06	14.48	18.12	21.8	26.2	32.8	39.4	40.0	40.0	40.0	40.0	40.0	40.0	40.0	40.0	40.0	40.0	40.0
	2000RPM	10.22	12.26	15.34	18.4	22.0	27.8	33.2	40.0	40.0	40.0	40.0	40.0	40.0	40.0	40.0	40.0	40.0	40.0
	2500RPM	9.28	11.14	13.94	16.74	20.0	25.2	30.2	36.4	40.0	40.0	40.0	40.0	40.0	40.0	40.0	40.0	40.0	40.0
	3000RPM	6.30	7.56	10.51	12.61	15.13	21.01	25.21	30.25	40.0	40.0	40.0	40.0	40.0	40.0	40.0	40.0	40.0	40.0

注Note: 表格中的□ (灰底部分) 表示旋转方向与电机转向一致。The □ (gray) in the table indicates that the rotation direction is consistent with the motor.
(不同转速及速比下的力矩为ZD标准驱动器下测试所得。The torque under different speed and speed ratio is obtained under the ZD standard.)